

Low Volatility Molecular Memory Based on Dynamic Doping of Conducting Polymers

Richard McCreery, Sudip Barman
Lian Shoute, Andrew Bonifas*
University of Alberta
*Ohio State University
National Institute for Nanotechnology

NRC-CNRC



UNIVERSITY OF
ALBERTA



**NSERC
CRSNG**



Canada Foundation for Innovation

National Institute for
Nanotechnology
University of Alberta,
Edmonton, Alberta,
Canada

Founded 2002
Building dedicated 2006

\$\$\$:

National Research Council
NSERC (Canada)
Alberta Ingenuity Fund
Canada Fund for Innovation



A possible application in microelectronics:

“DRAM”: (fast, forgetful)

- based on charge storage on a capacitor
- retention time < 100 msec
- density limited by capacitor size
- read/write/erase < 50 nsec

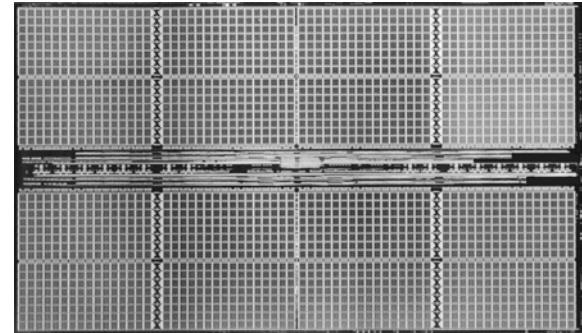

can we fill this memory “hole” with molecular devices?

“Flash”: (slow, persistent)

- based on floating gate FET
- write > 25 μ sec
- erase \sim 1 msec
- limited cycle life ($\sim 10^5$)
- retention \sim 10 years

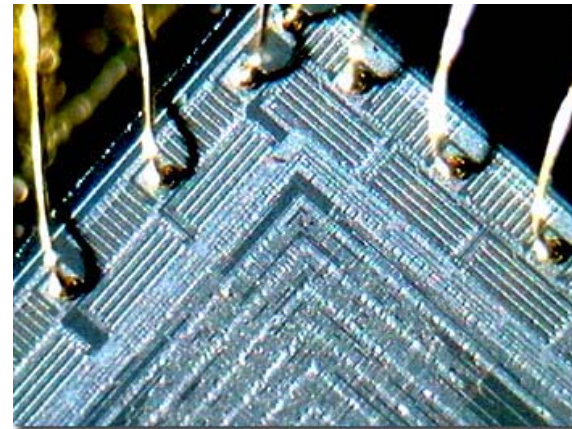

"Molecular junctions:"

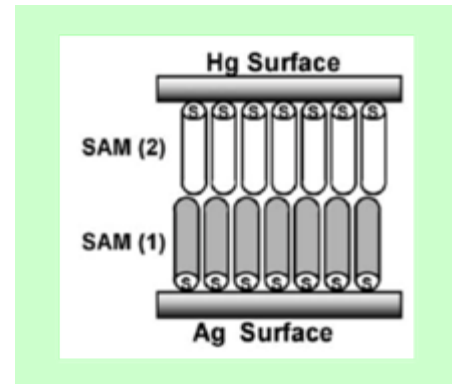
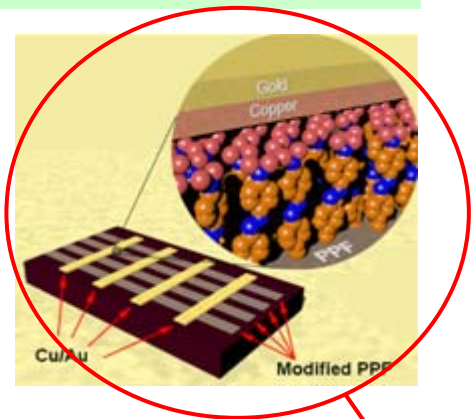
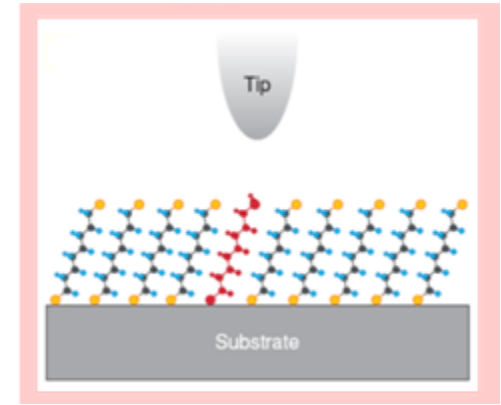
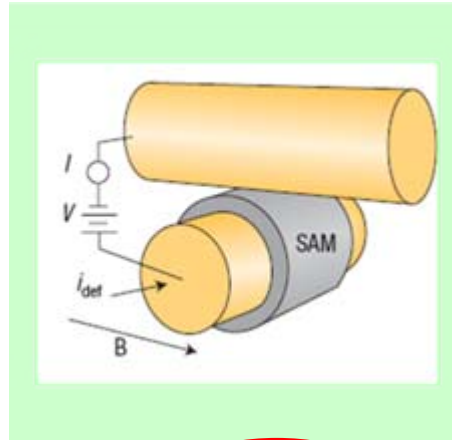
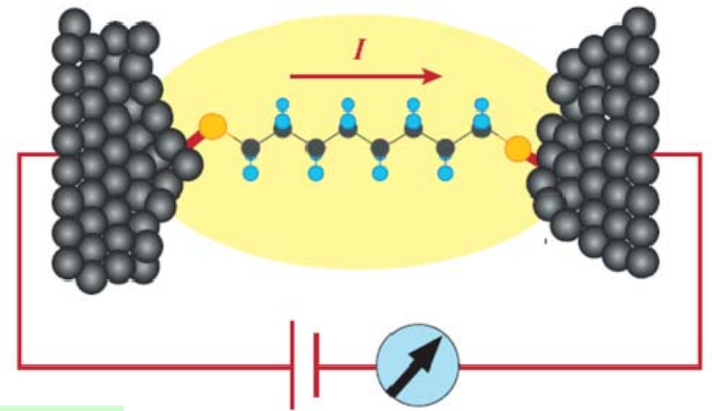

next slide

Molecular heterojunction:

200 μm

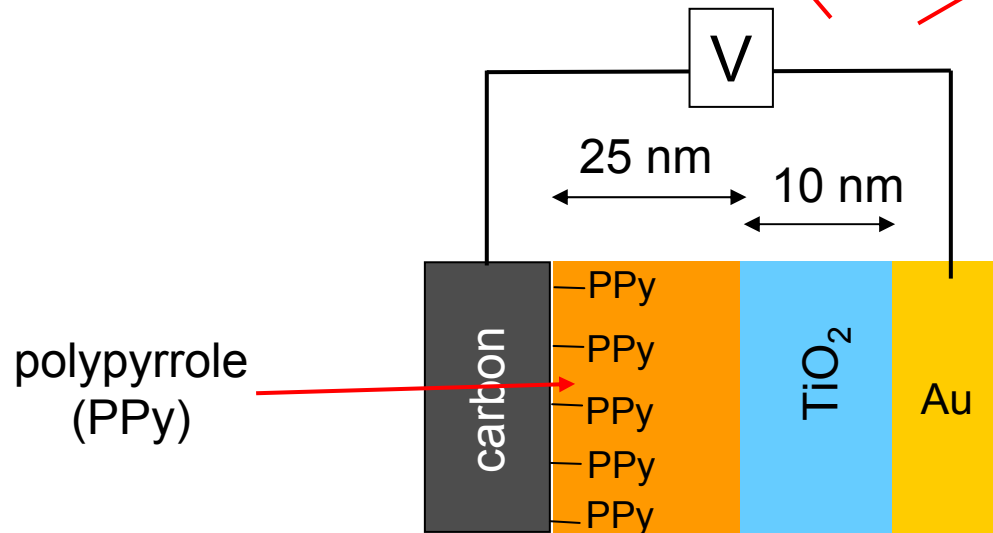
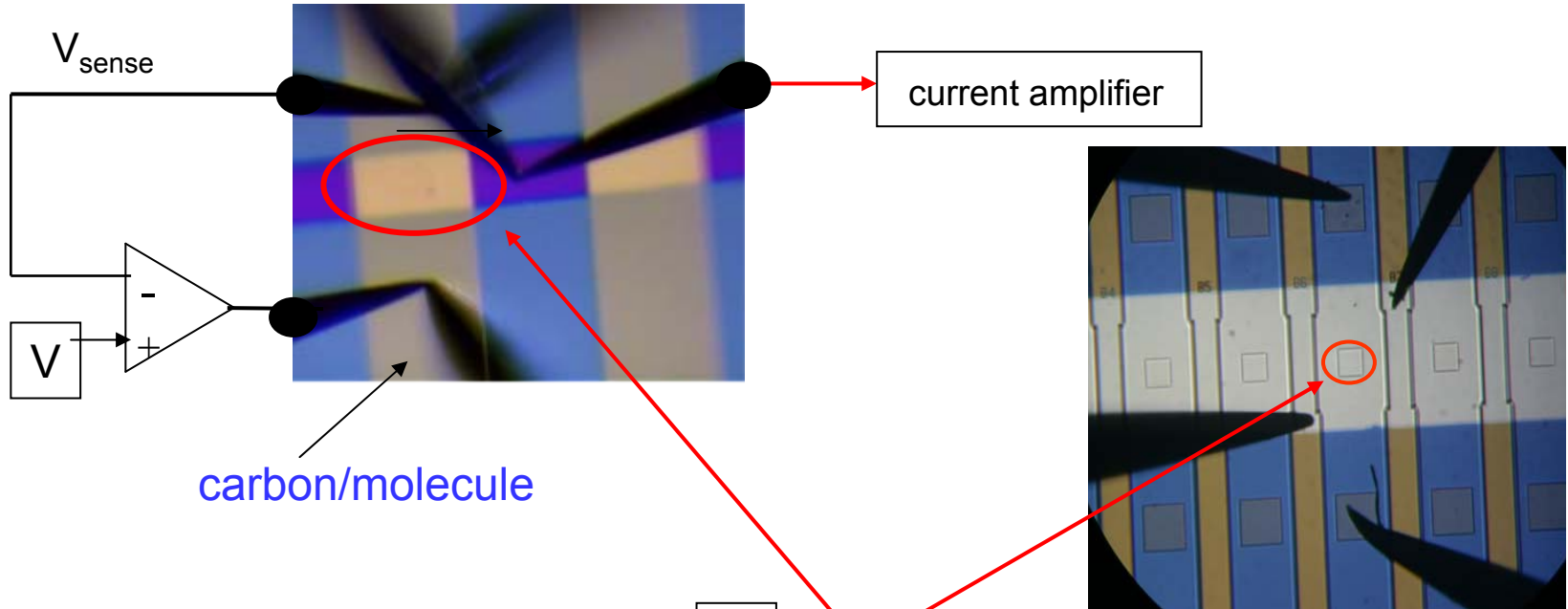

1. a really flat substrate:

photoresist spin coated on Si substrate

1000 °C

H₂/N₂

5 nm

2 4 6 8
μm

Pyrolyzed Photoresist Film (PPF)

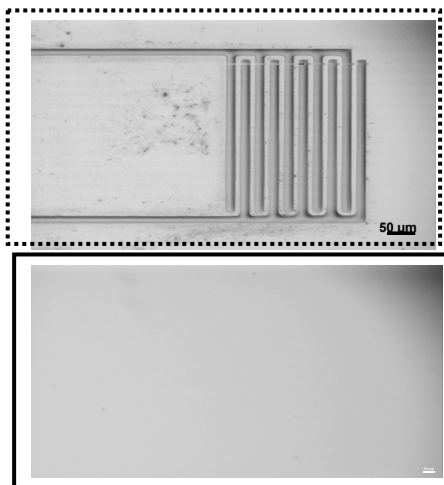

RMS Roughness < 5 Å

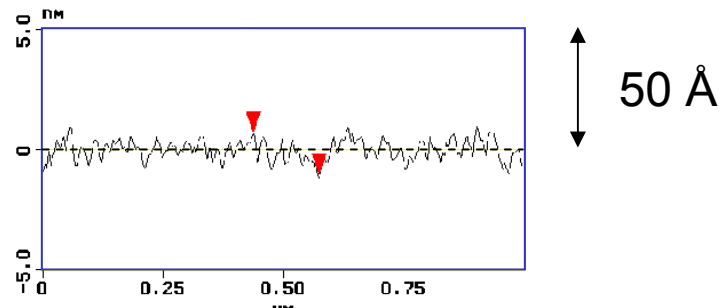

Ranganathan, McCreery, Majji, and Madou, *J. Electrochem. Soc.*, **2000**, 147, 277–282
Ranganathan, McCreery, *Anal. Chem*, **2001**, 73, 893-900.

2. electrochemical deposition of polypyrrole on PPF:

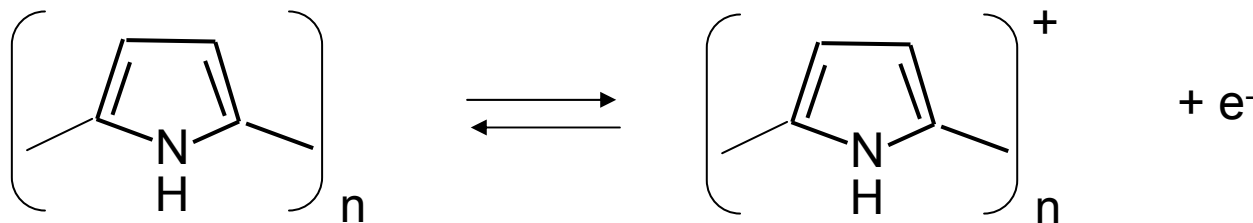
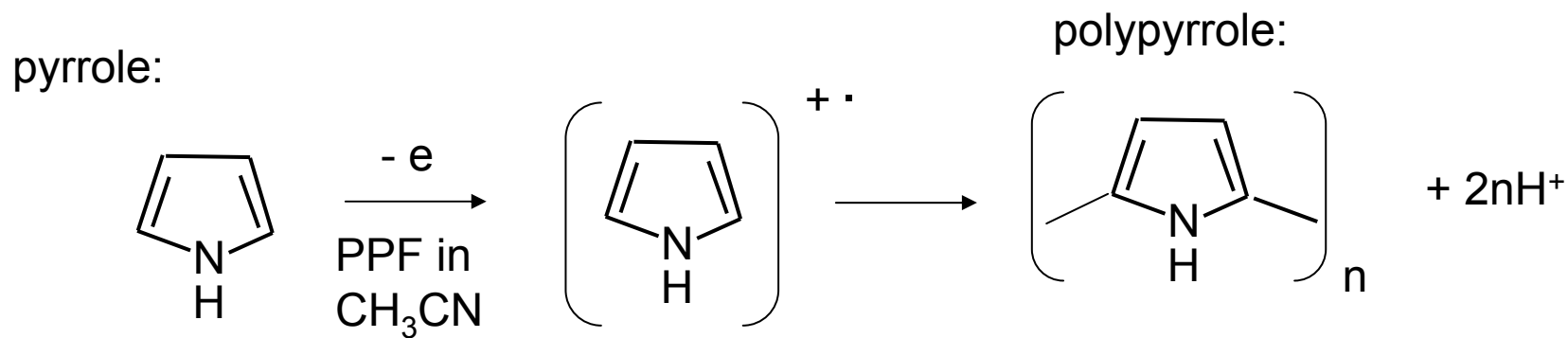

conductivity $\sim 10^{-9}$ S/cm

conductivity ~ 100 S/cm

Prepared by

Const current = $-100\mu\text{A}$ for 150 sec.

Then Const. Potential = -1V for 75sec.

3. deposit TiO_2 and Au by e-beam evaporation:

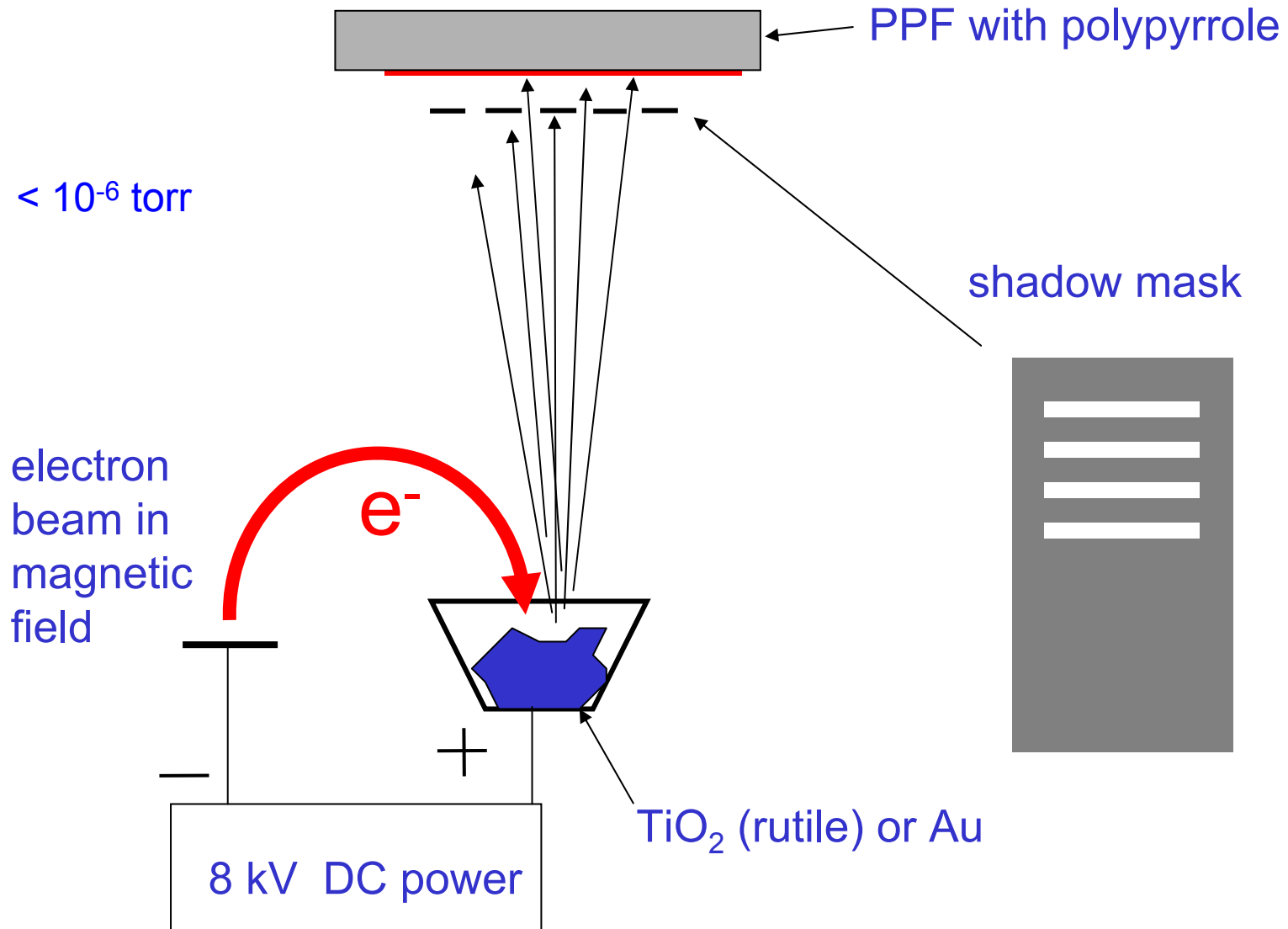

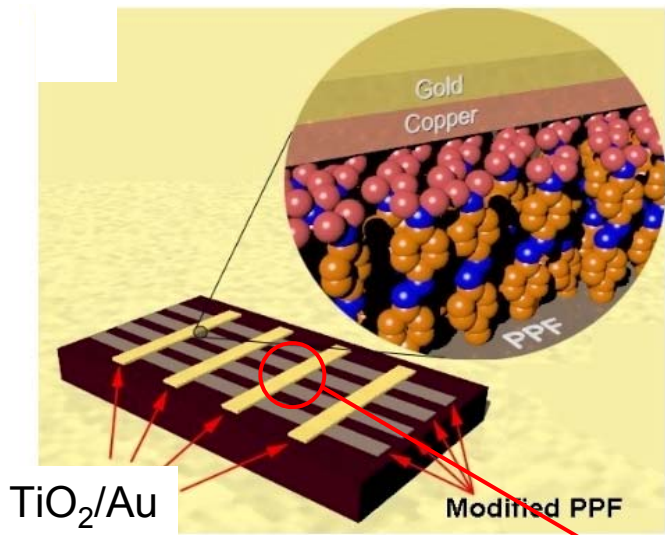

PPF/PPy

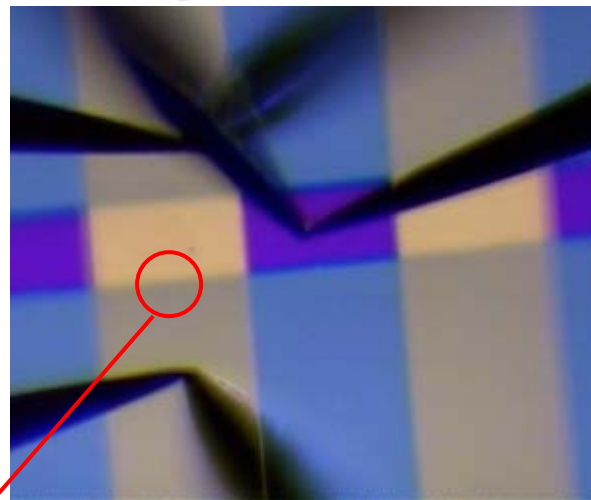

TiO_2/Au

next slide

J. Am. Chem. Soc. **2004**, 126, 16621
Phys. Chem. Chem. Phys., **2006**, 8, 2572
J. Chem. Phys. **2007**, 126, 024704

“Edge” view of cleaved junction:

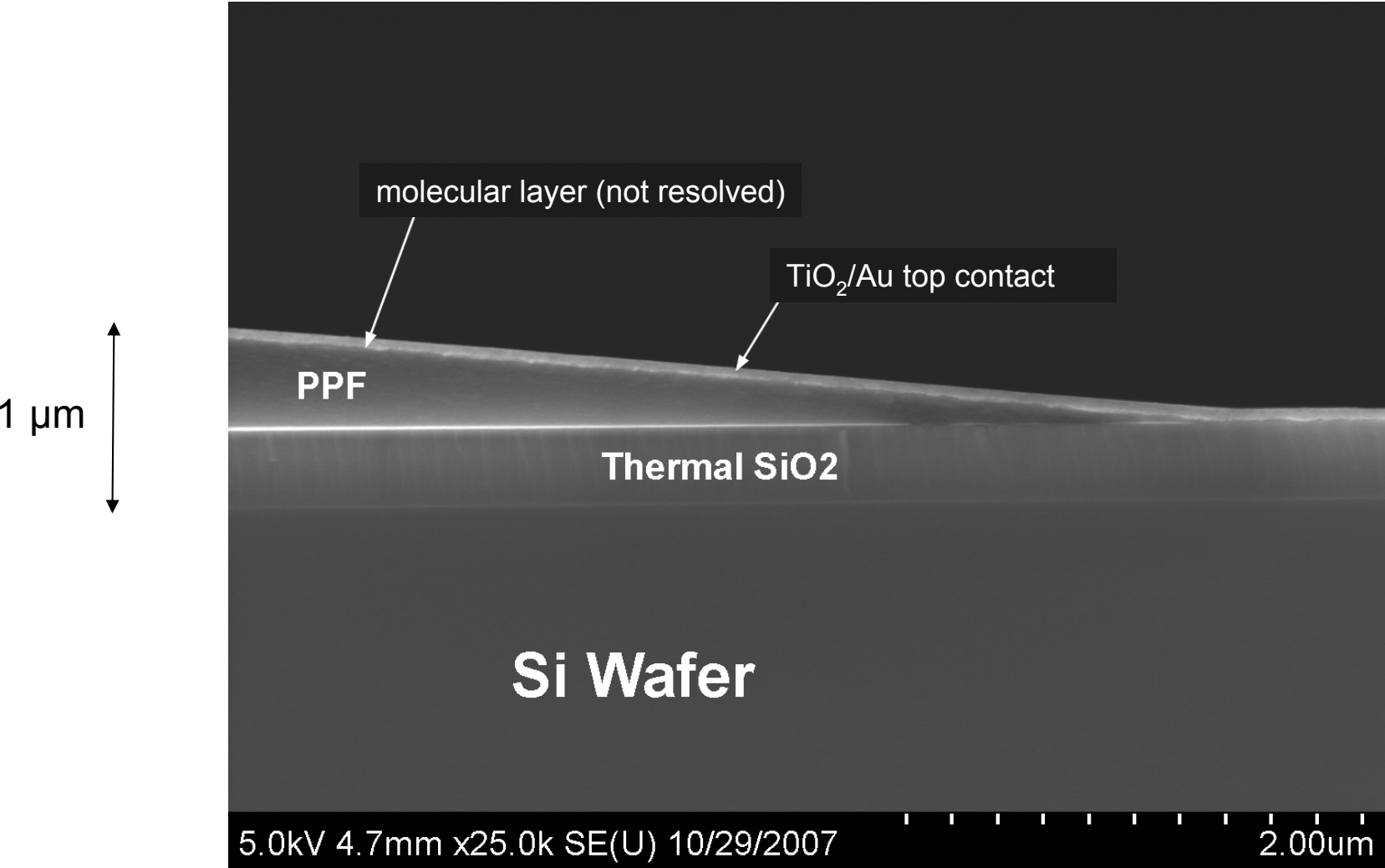

TEM cross sections (Doug Vick, Peng Li)

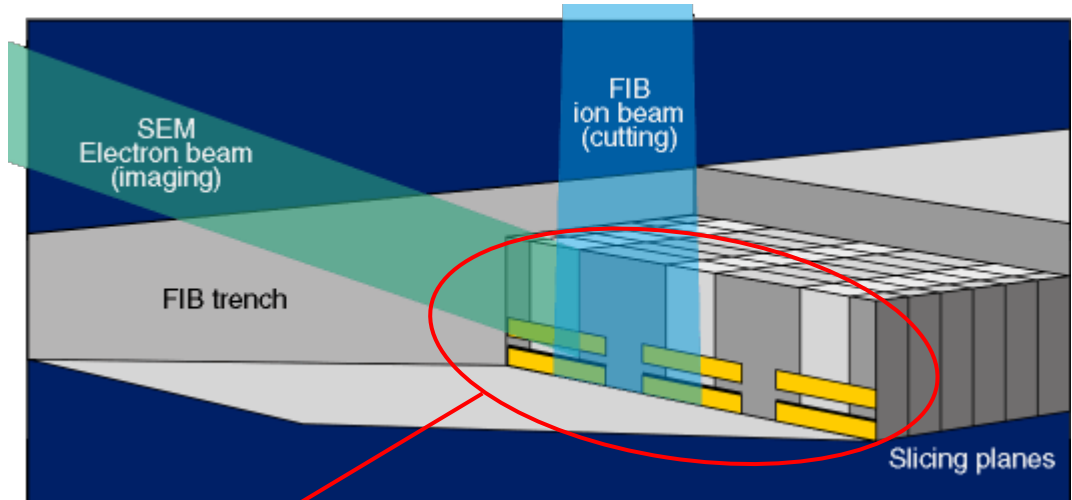
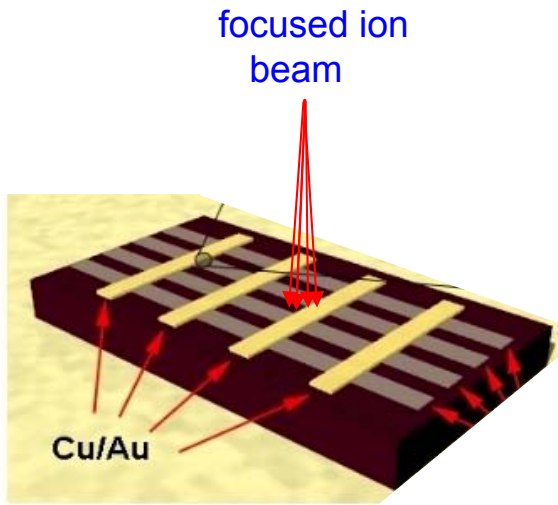

FIB/SEM

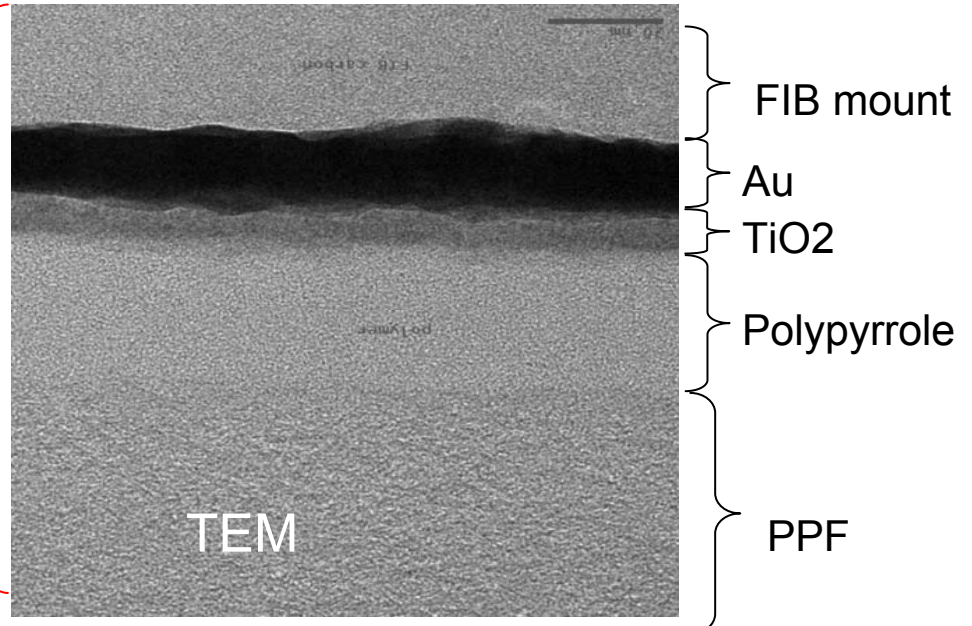
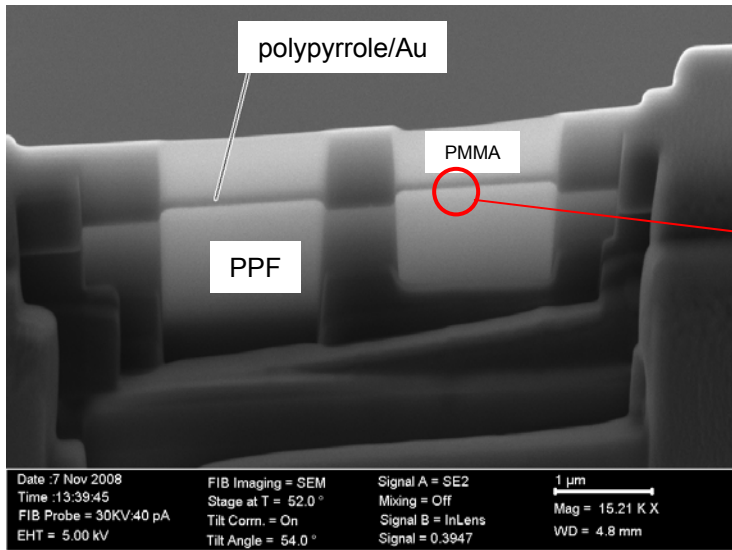

20 nm

memory 1 μm

Electronic characterization:

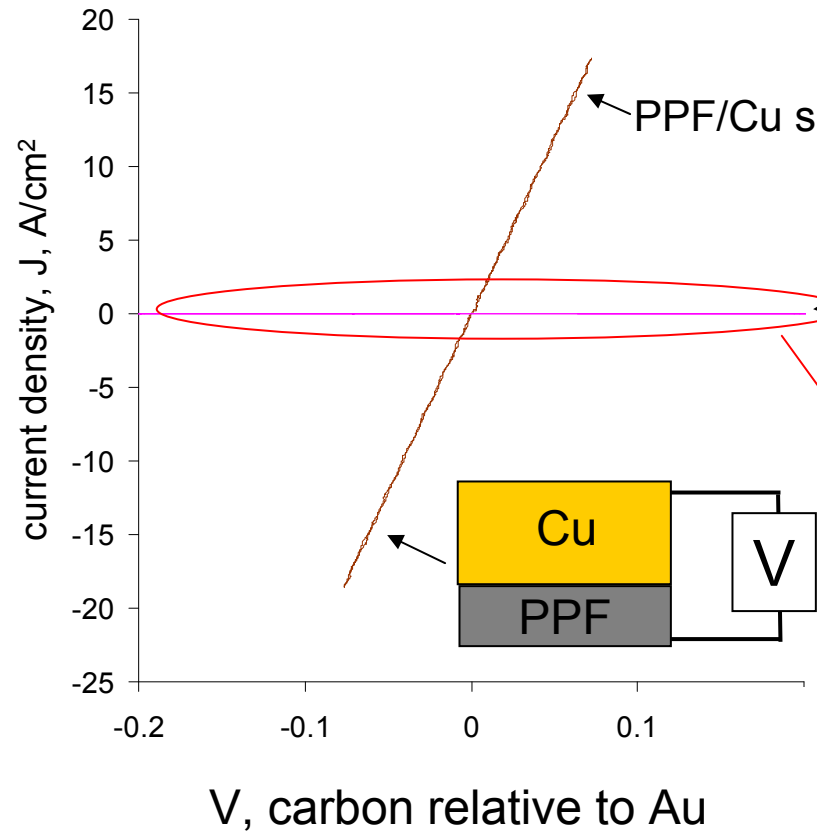

PPF/SiO₂/Cu

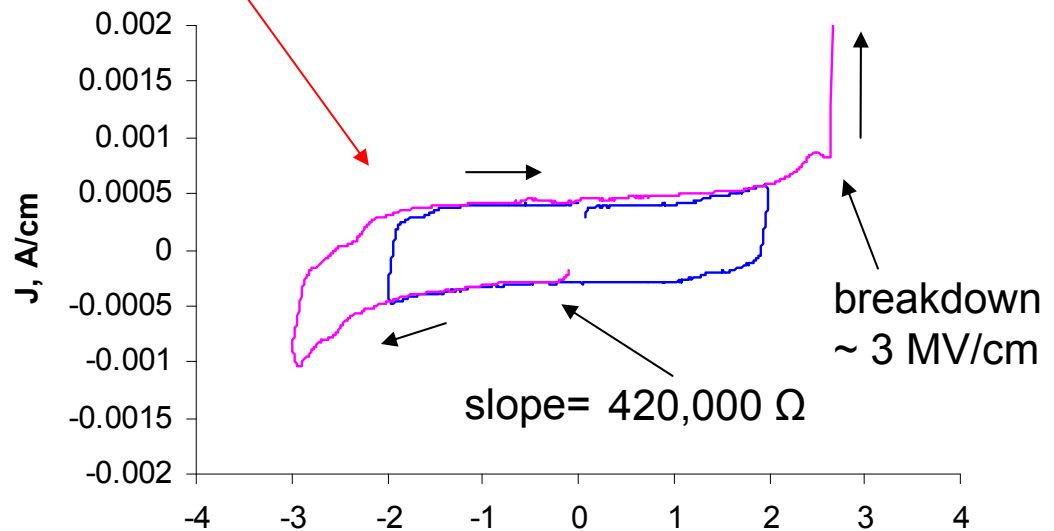
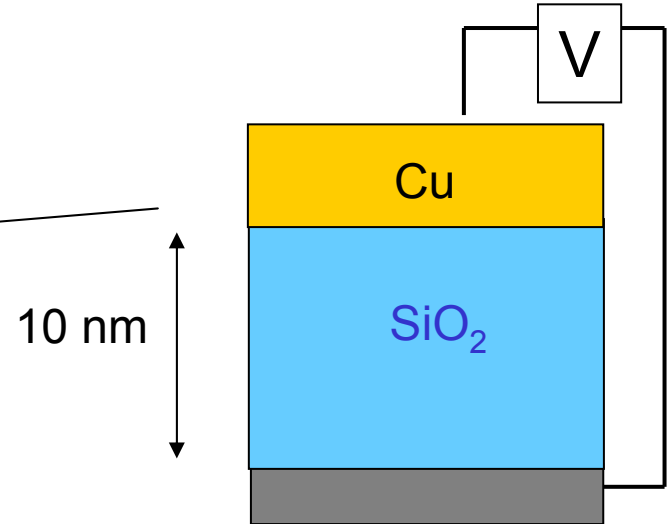

PPF/polypyrrole/Au:

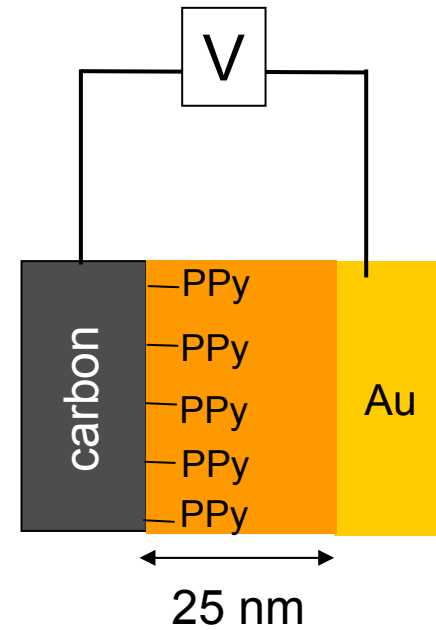
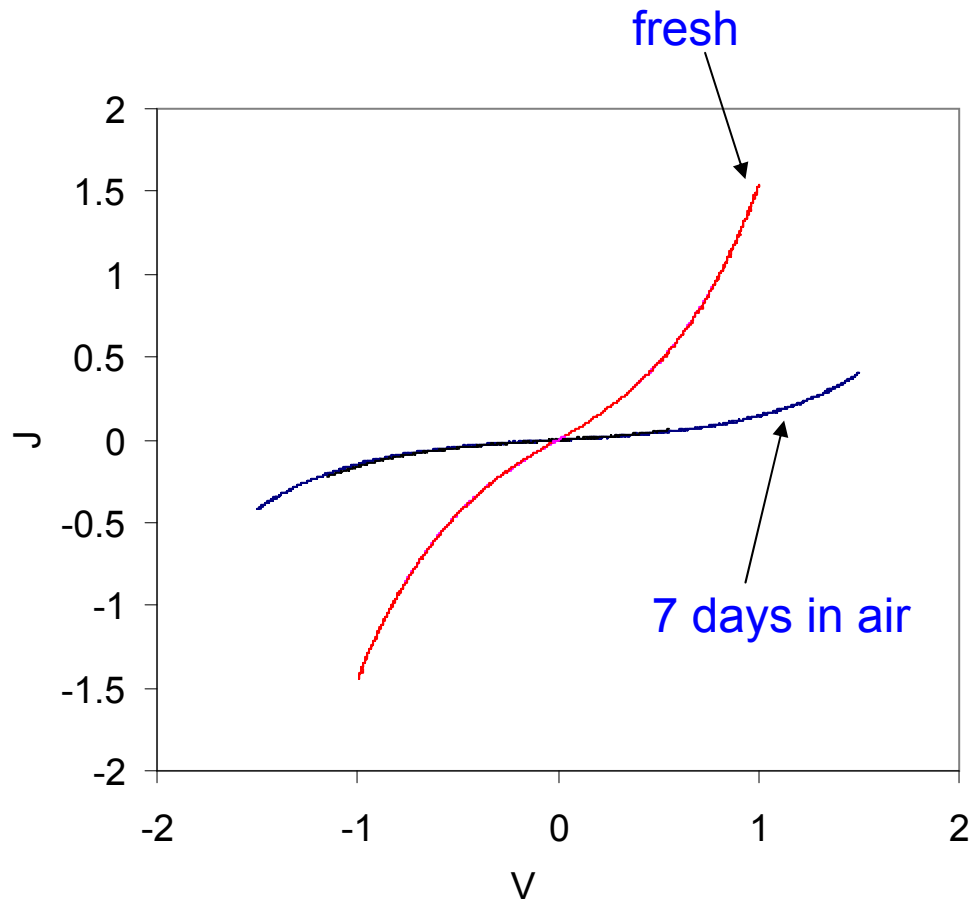

Strange behaviour when TiO_2 is combined with PPy in “molecular heterojunction”...

J. Chem. Phys. **2007**, 126, 024704
J. Electrochem Soc. **2009**, 156, 29-37

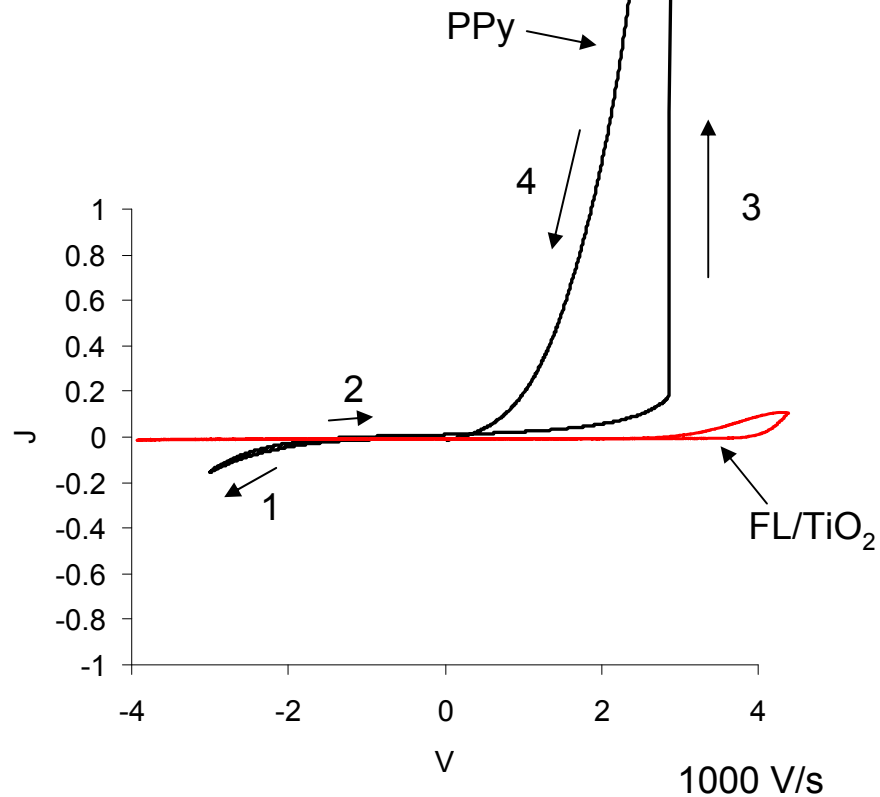
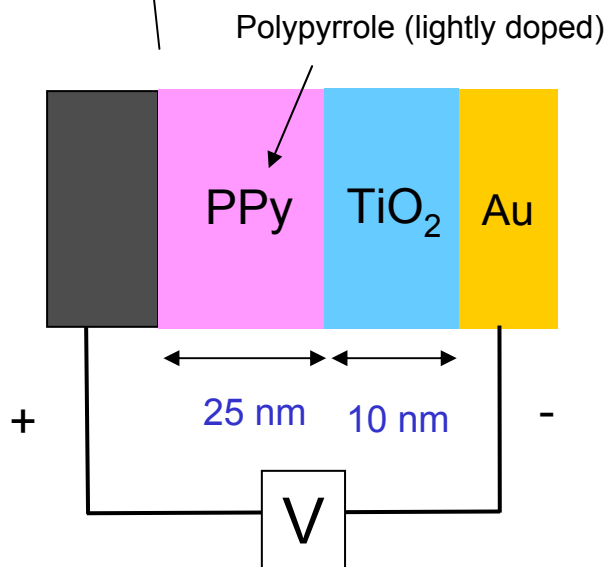
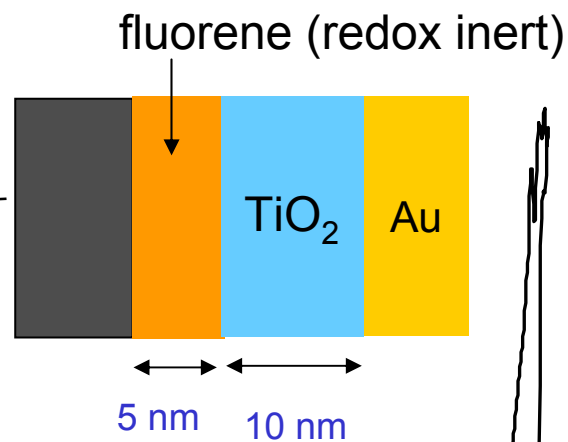
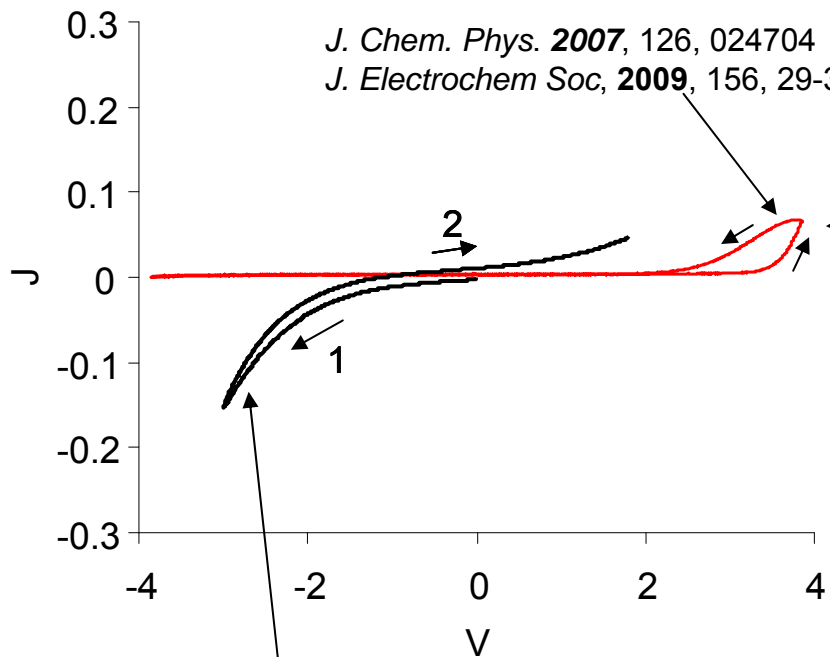

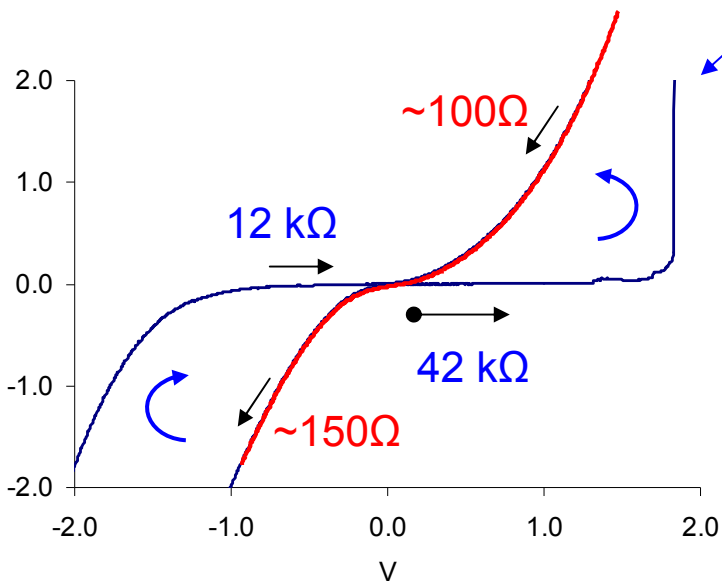
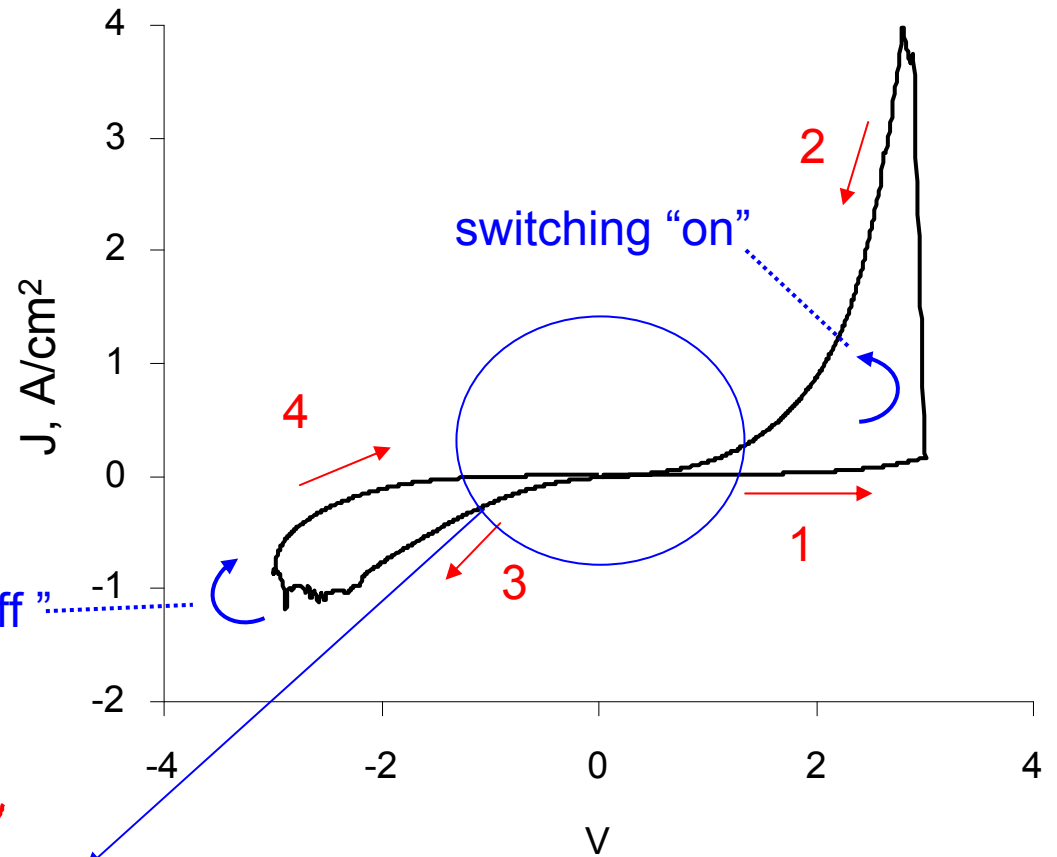
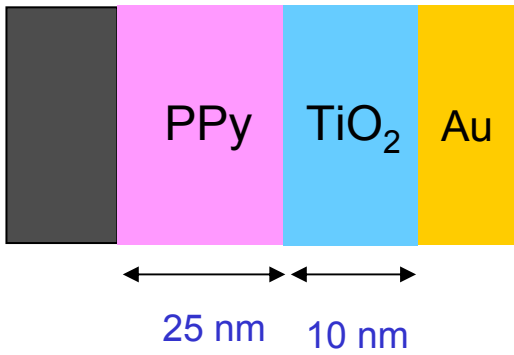

pronounced hysteresis in both directions

~ 100 Ω is "set" state
 > 10 K Ω is "erased" state

1000 V/s

A complete read/write/read/erase/read cycle:

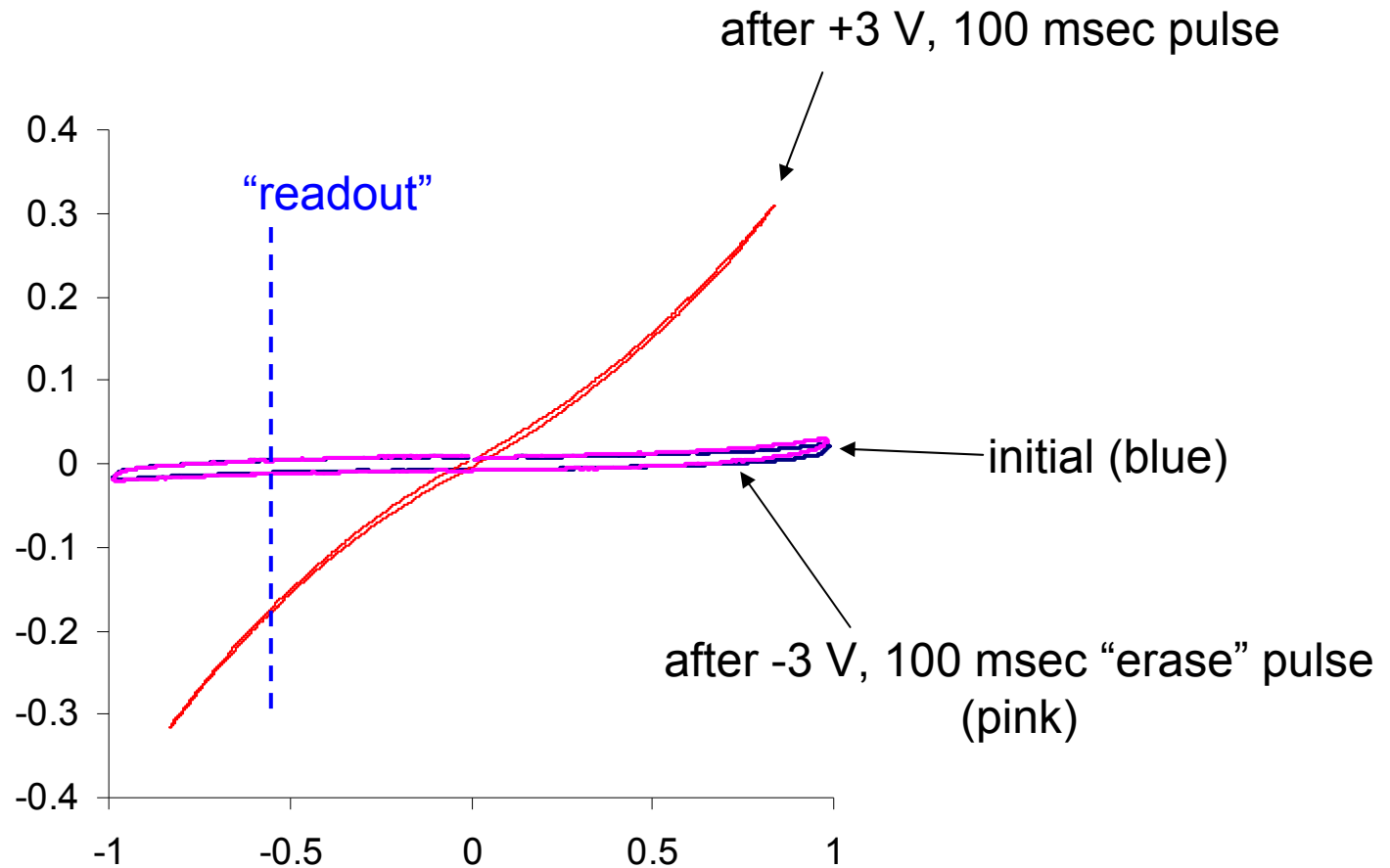
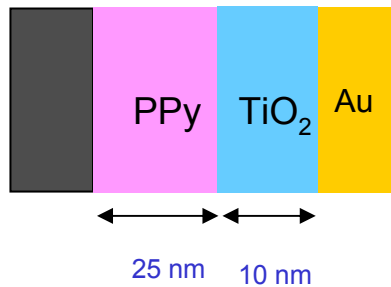

How fast?

+ 3 V "set" pulses:

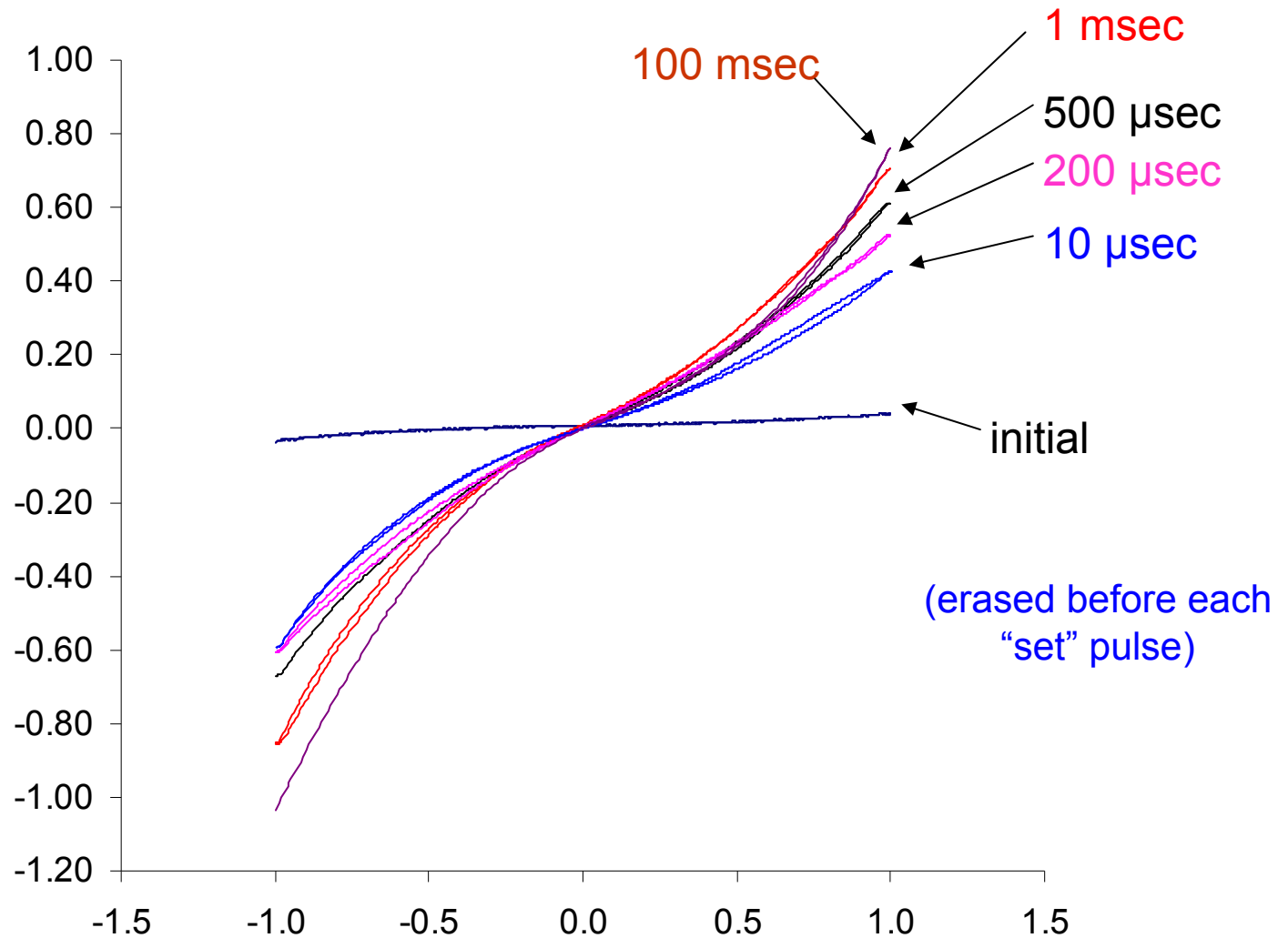

So far, we have demonstrated submicrosecond write speed
(DRAM ~ 50 nsec; flash ~25 µsec)

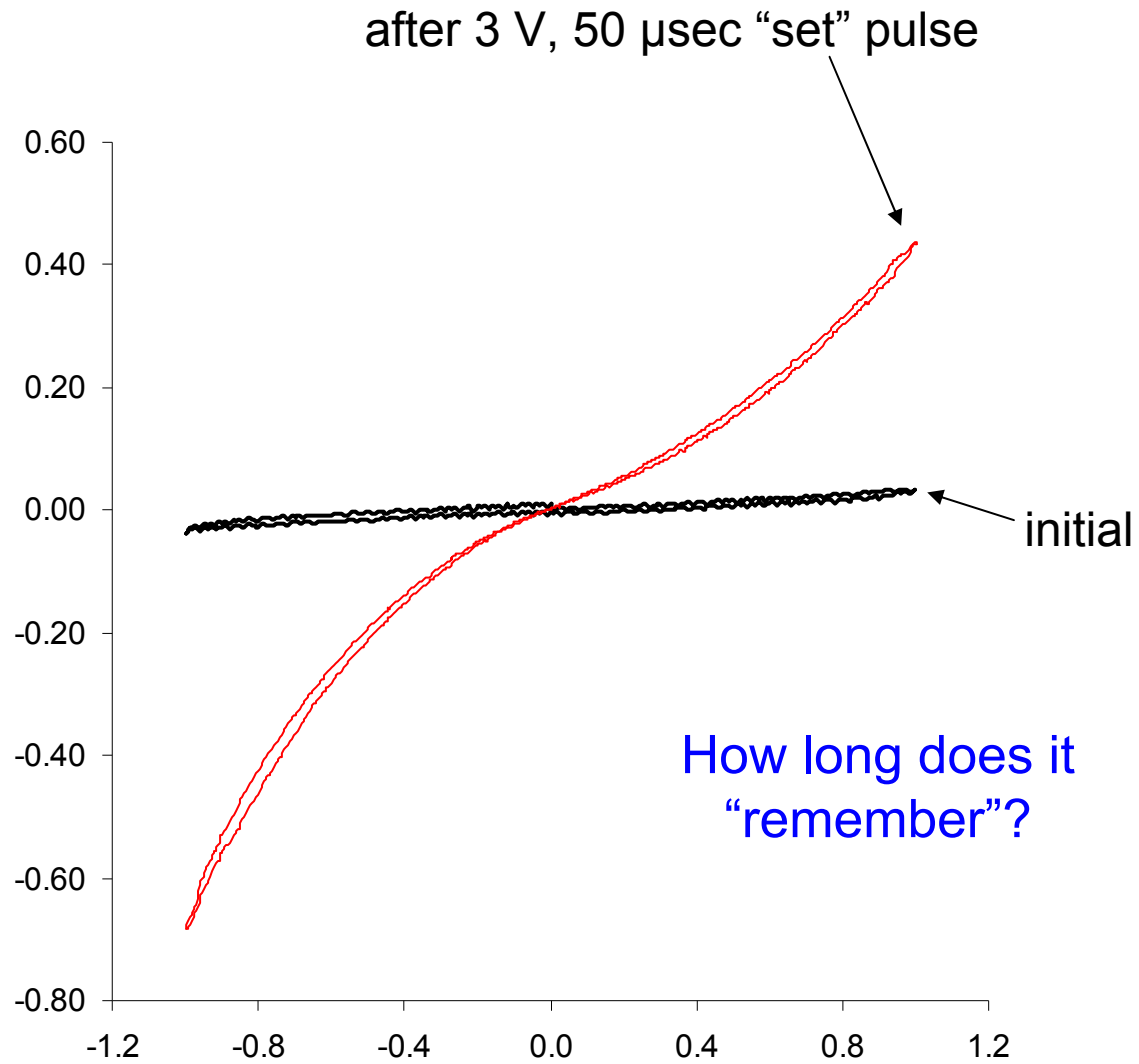

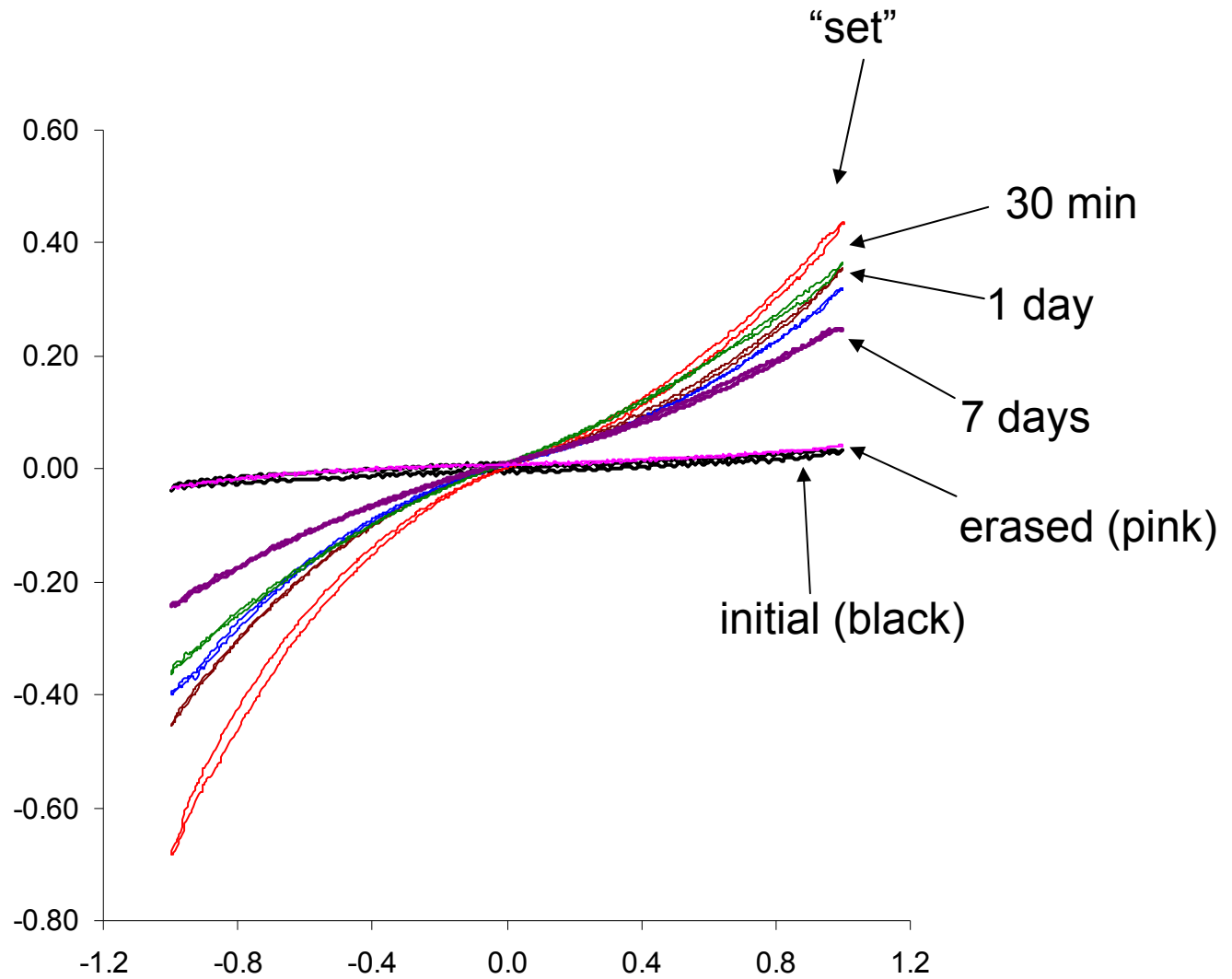

> 7 day retention of ON or OFF state (in air)
(DRAM ~ 60 msec; flash > 1 year)

Cycle Life:

repetitive
read/set/read/erase
cycles

100 msec, ± 3 V, "torture test"

write, erase: $< 1 \mu\text{sec}$
retention: > 7 days
cycle life: > 1600 w/r/e/r cycles

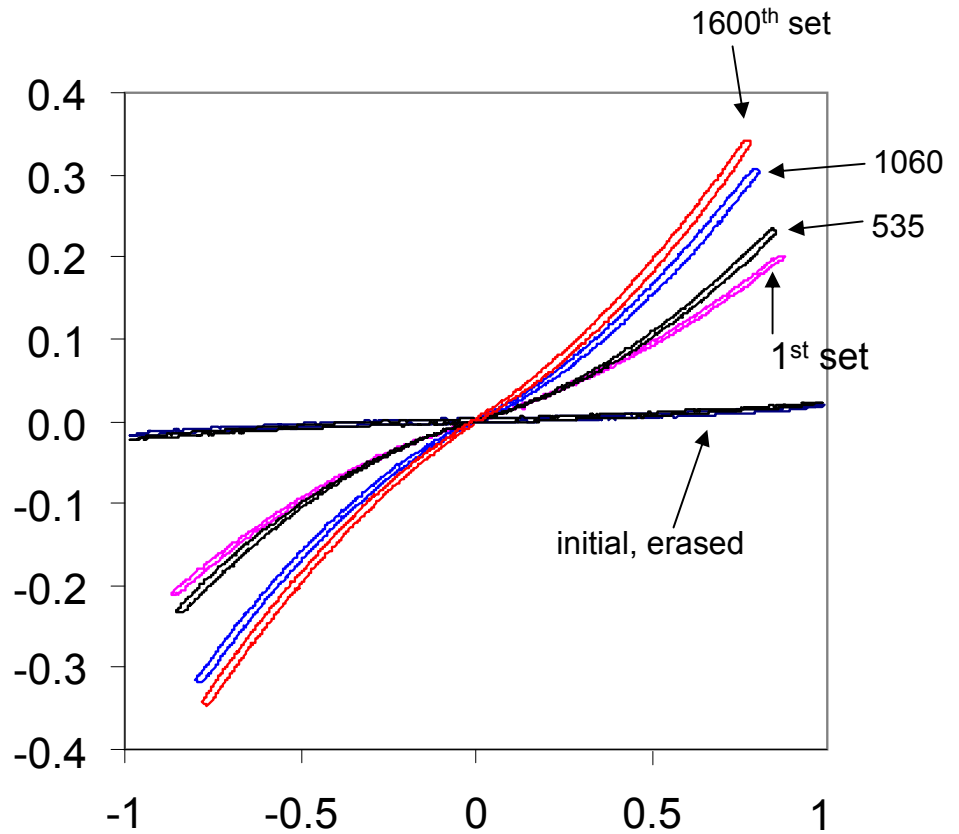

} attractive performance, but how does it work?

Working hypothesis:

+ bias
("write")

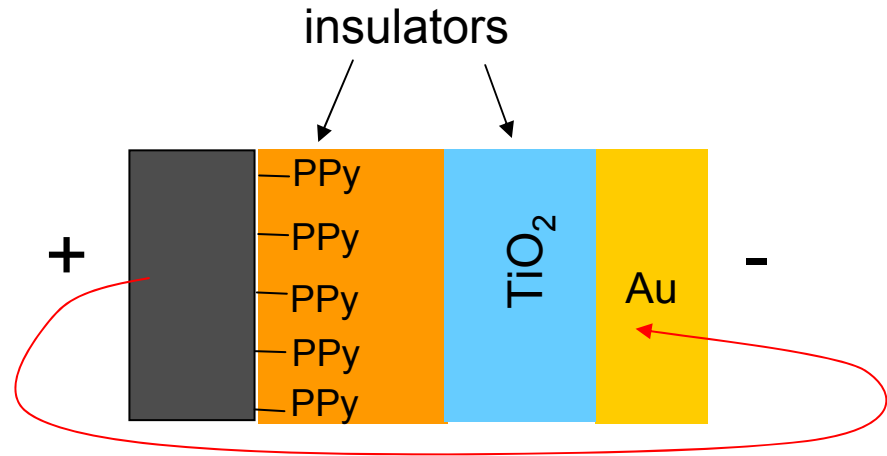

bias-induced oxidation
of polypyrrole to a
conductive state, i.e.
"dynamic doping"

+ bias ("write") -bias ("erase") e^-
bias induced, solid state redox process

to test the hypothesis:

- in-situ spectroscopy
- change contact materials
- leave out TiO_2
- temperature effects

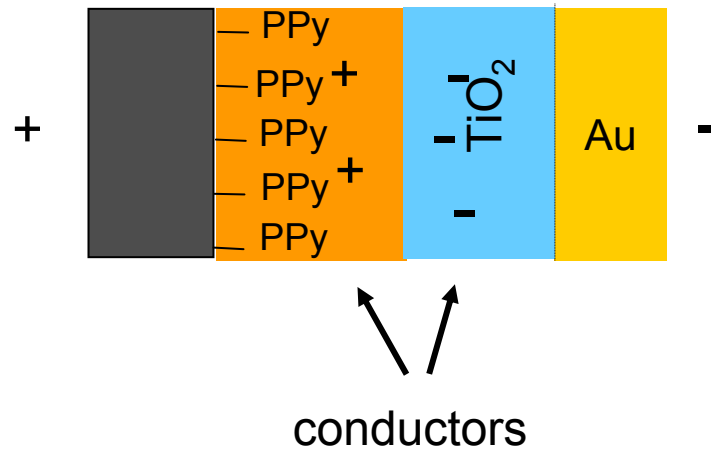

Optically transparent
molecular junction:

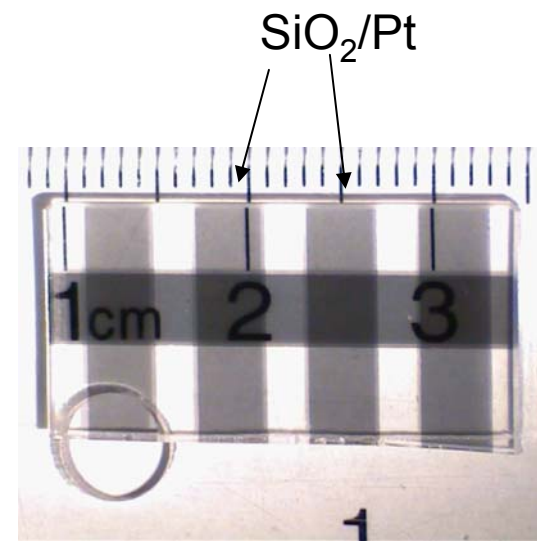
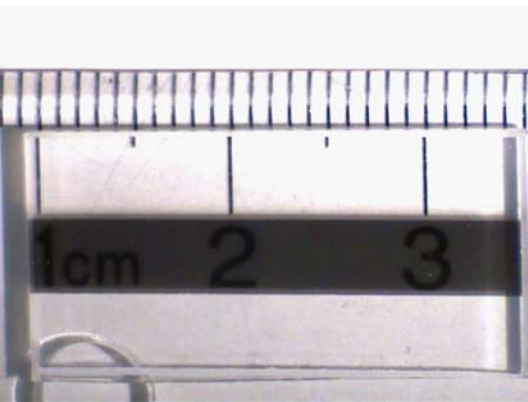
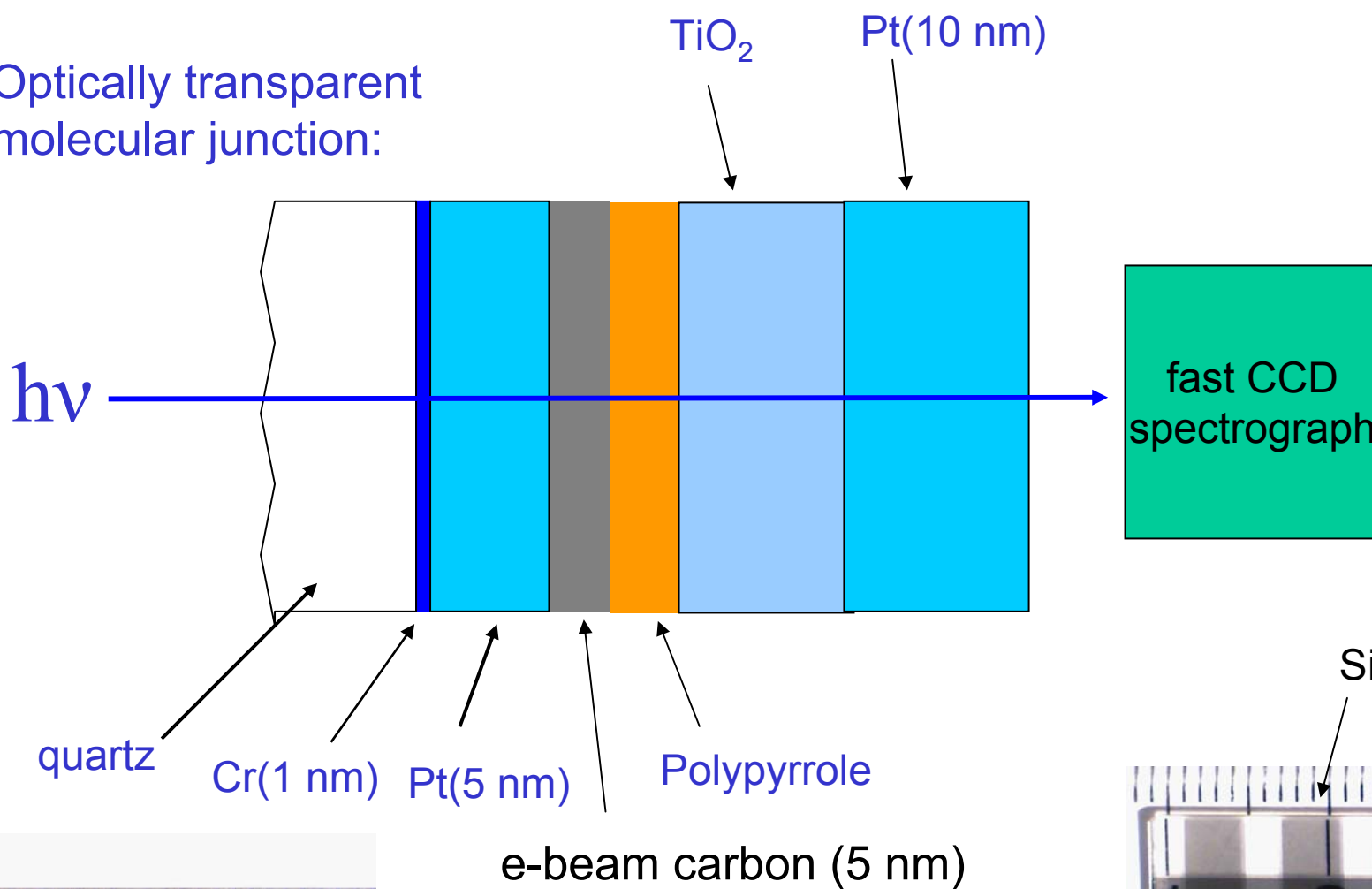

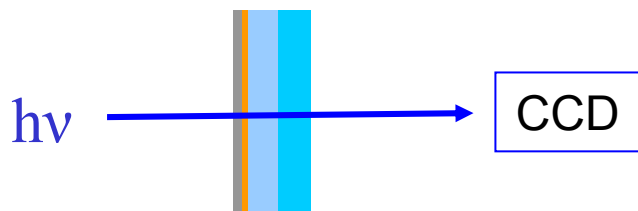

light source, CCD, etc

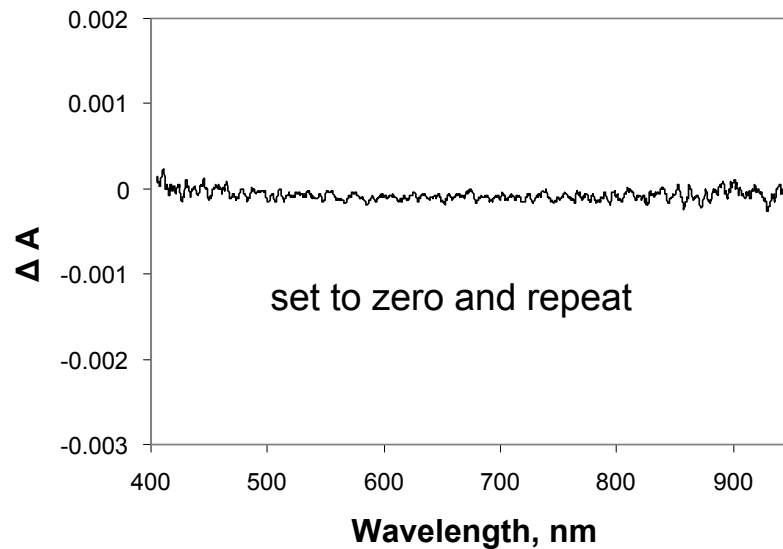
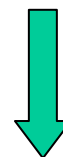
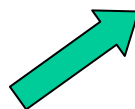
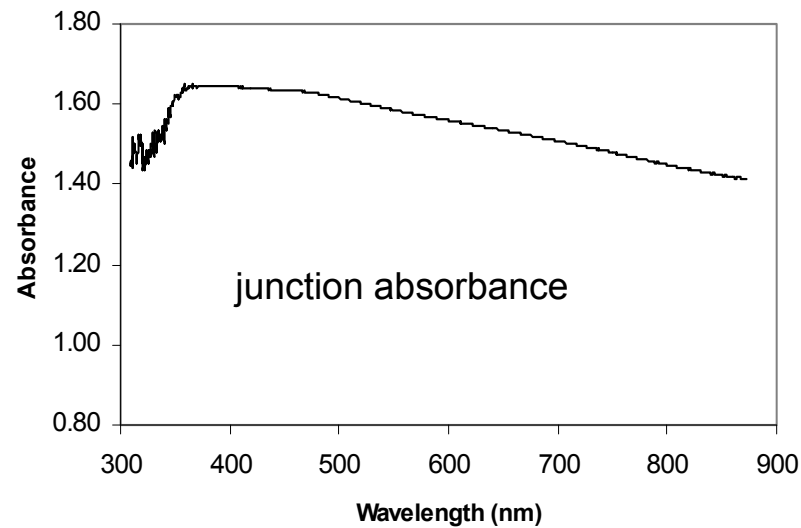
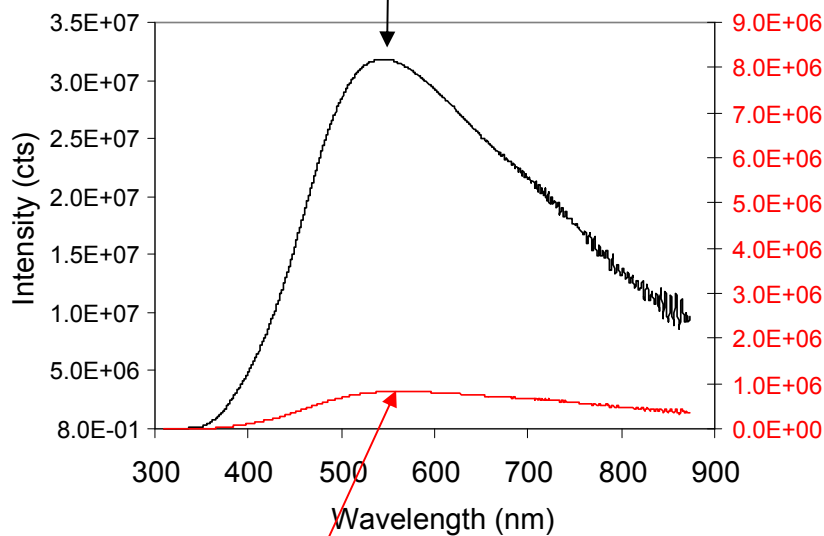

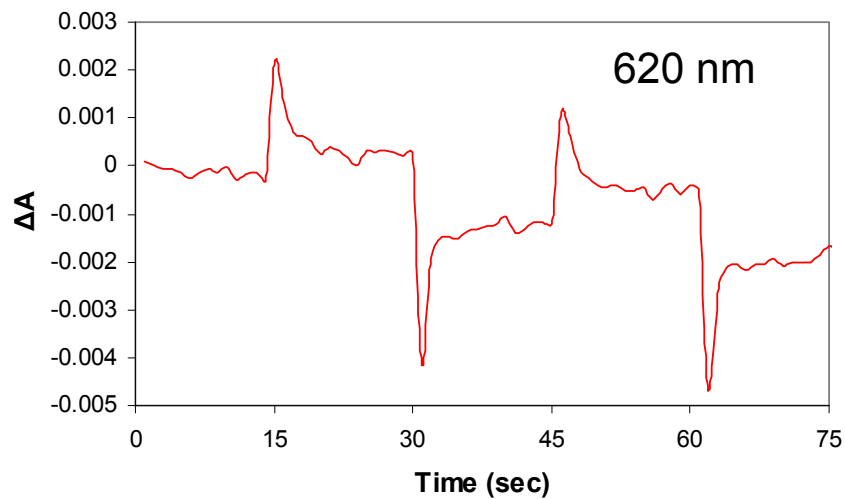
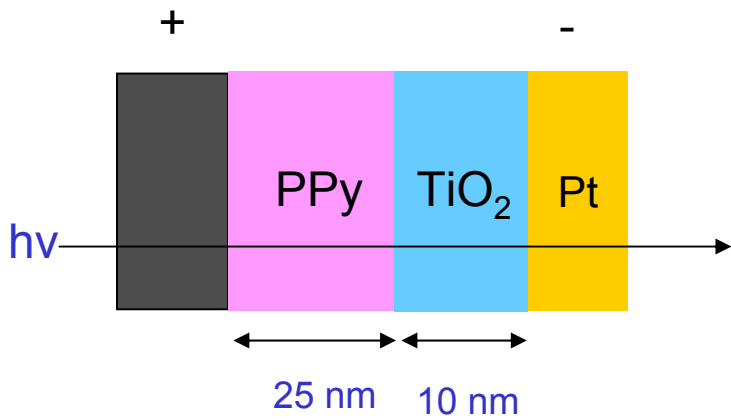
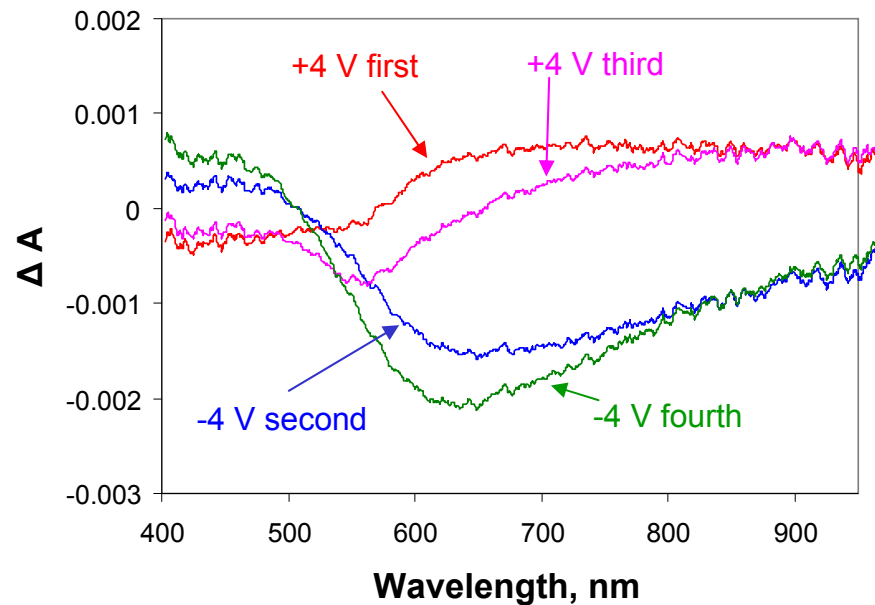
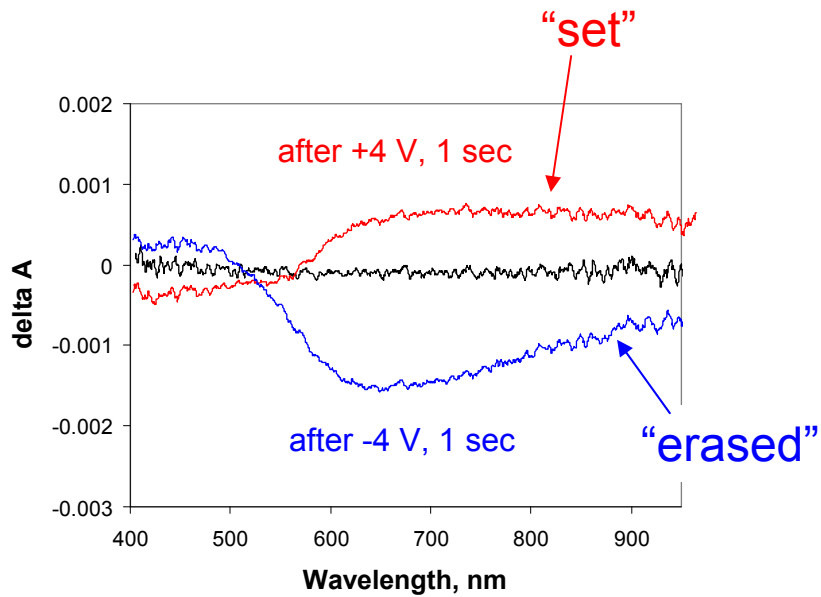

optical response limited by RC and integration time, but < 100 msec

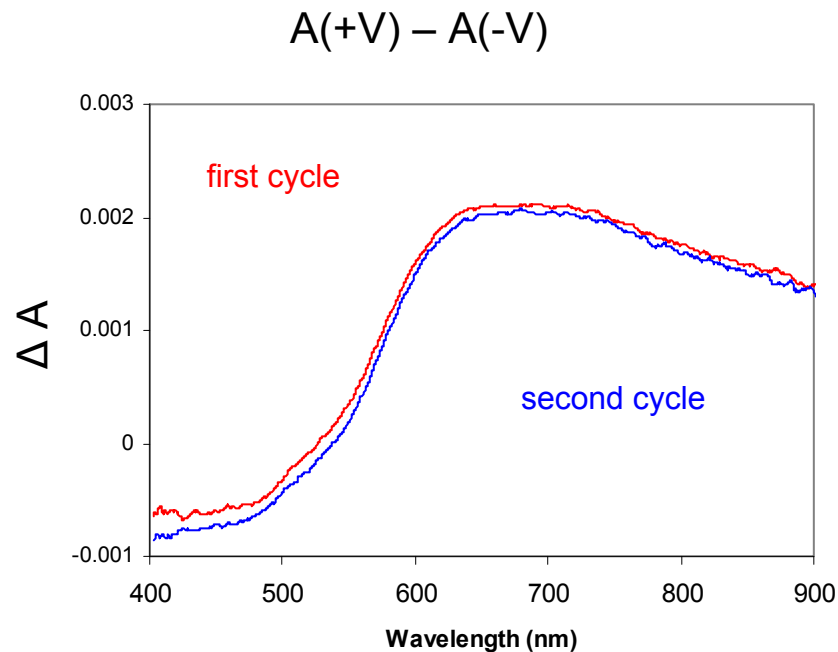

Q/Pt/carbon/PPy in solution
electrolyte:

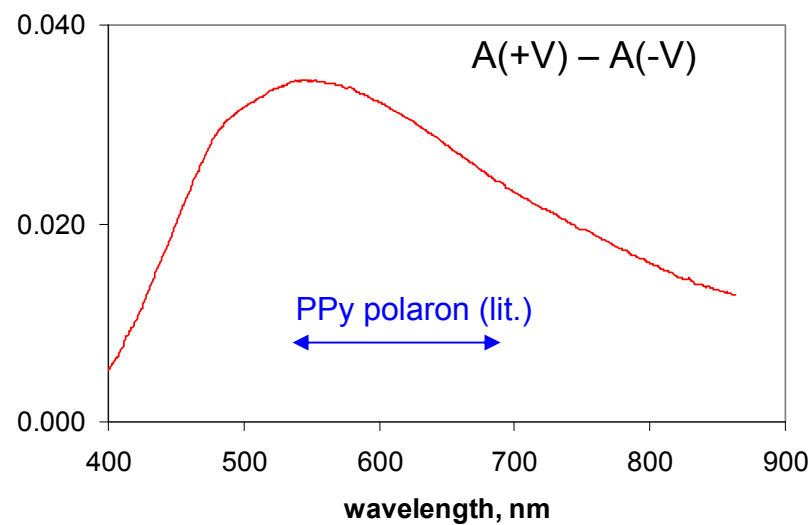
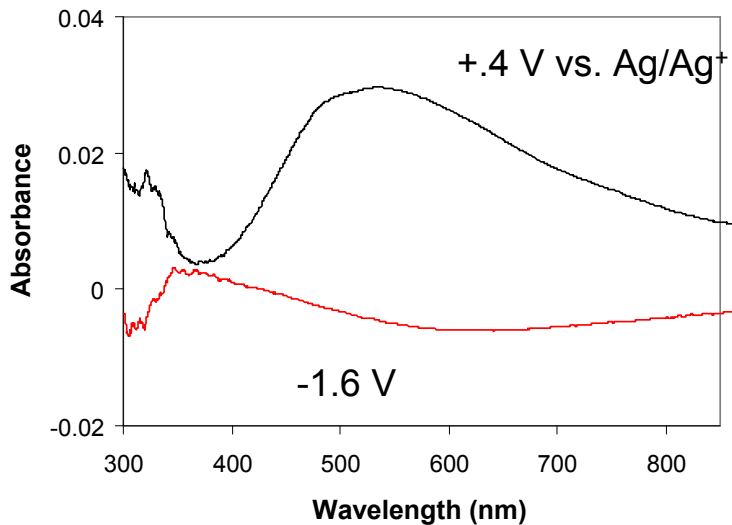

Direct evidence for polypyrrole oxidation, but not structurally specific

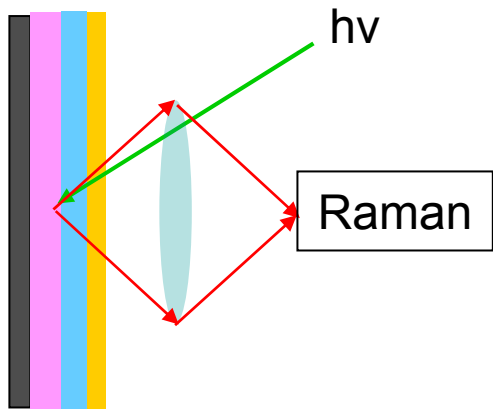

after -3 V,
300 sec

after -3 V,
60 sec

after -3 V,
20 sec

after +3 V,
20 sec

after +3 V,
60,300 sec

initial
(oxidized)

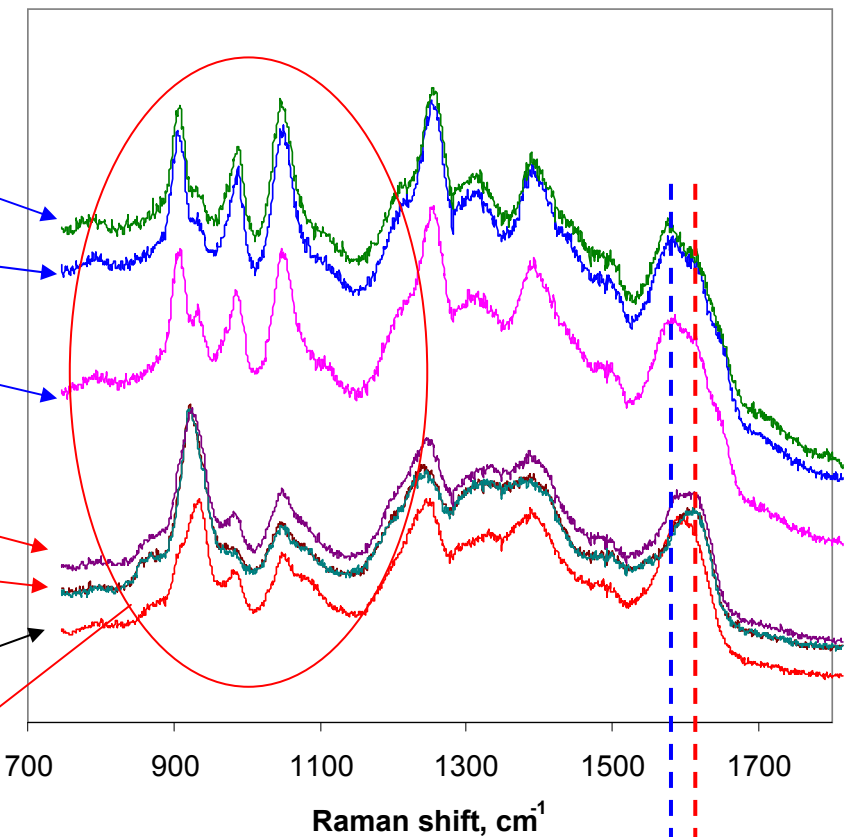

neutral*

polaron*

polaron

neutral

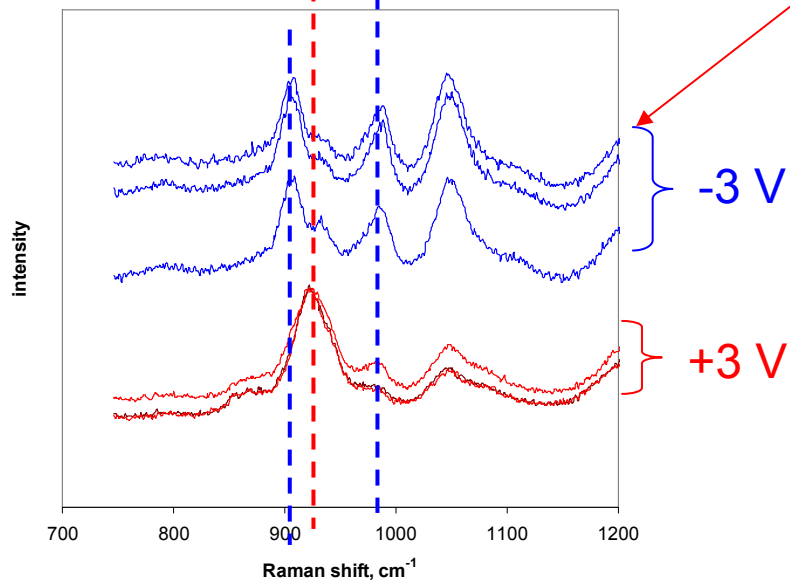

Spectroscopy indicates that PPy is oxidized or reduced by bias pulses

*Santos, Brolo, Girotto, *Electrochimica Acta* **2007**, 52, 6141.
Liu, Hwang,.; Jian,.; Santhanam, *Thin Solid Films* **2000**, 374, 85.

Spectroscopy proves that PPy is oxidized and reduced by applied bias.

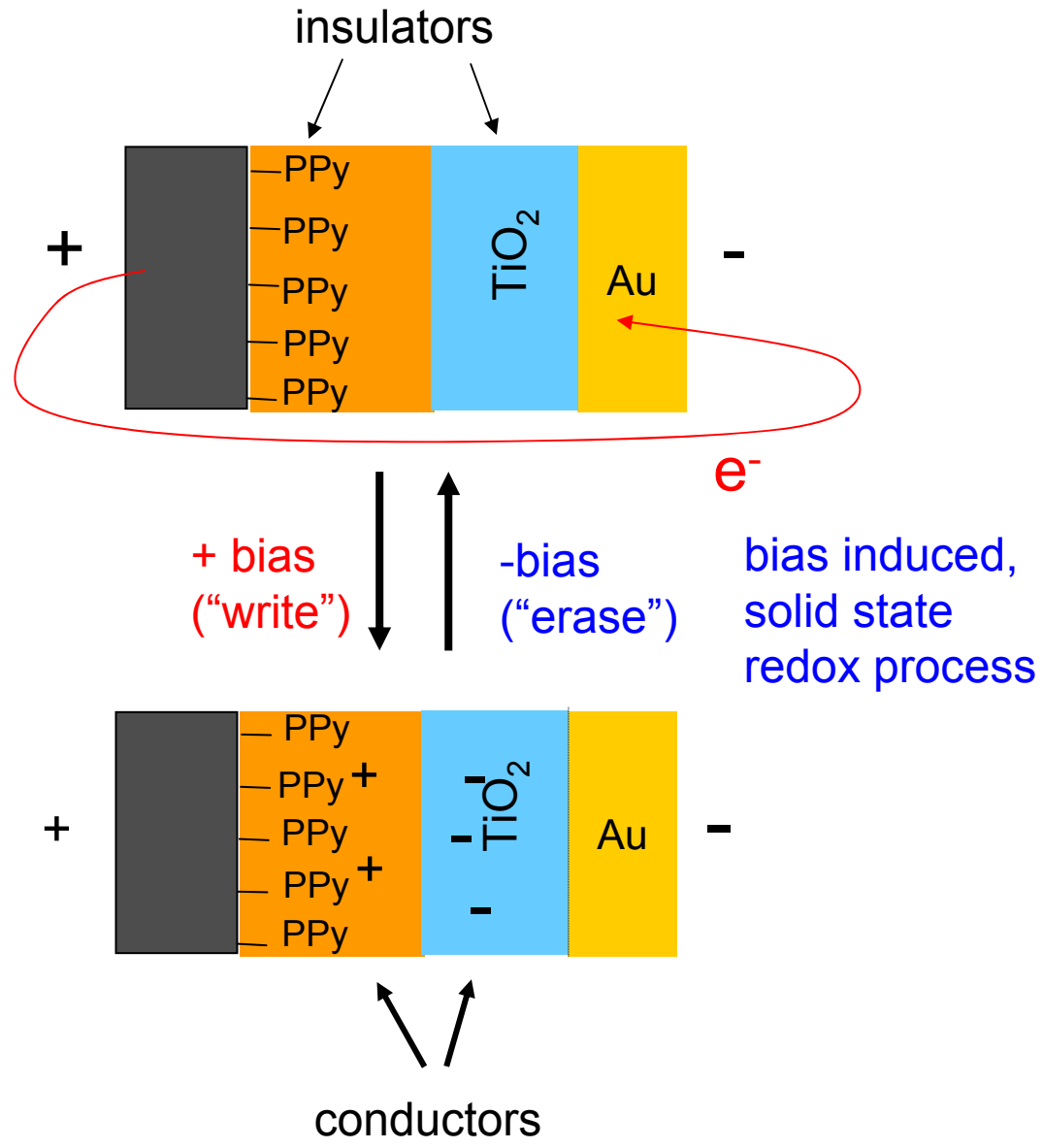

Conductivities:

PPy (undoped) $\sim 10^{-9}$ S/cm
 PPy⁺ (oxidized) ~ 10 S/cm

Ti^{IV}oxide: $\sim 10^{-4}$ S/cm
 Ti^{III}oxide $\sim 10^4$ S/cm

Potentially $> 10^8$ change in conductance with redox activity

A possible application in microelectronics:

“DRAM”: (fast, forgetful)

- based on charge storage on a capacitor
- retention time < 100 msec
- density limited by capacitor size
- read/write/erase < 50 nsec

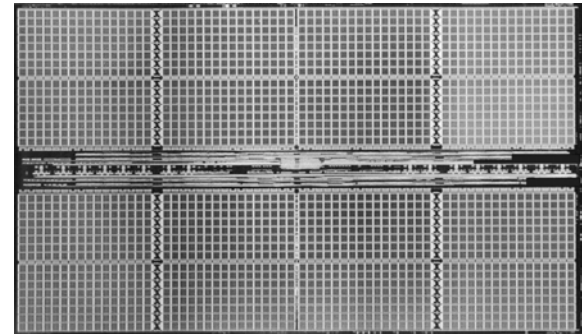

< 10 usec write speed, 1 week retention might fill a niche

“Flash”: (slow, persistent)

- based on floating gate FET
- write > 25 μ sec
- erase \sim 1 msec
- limited cycle life ($\sim 10^5$)
- retention \sim 10 years

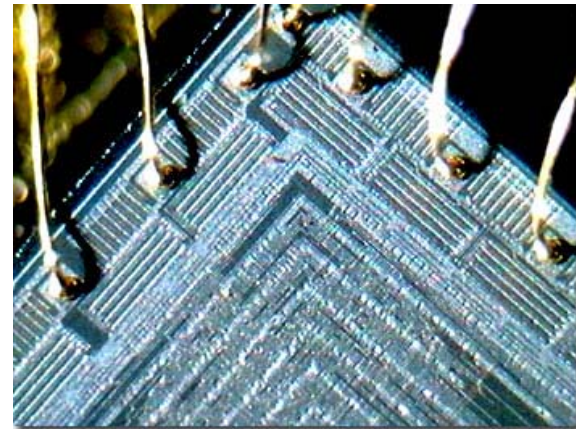

Adam Bergren (NRC)
Andrew Bonifas (OSU mat. sci.)
Sudip Barman (U of A postdoc)
Lian Shoute (U of A postdoc)
Haijun Yan (OSU chemistry)
Sergio Jimenez (visit. prof.)

\$\$\$:

National Research Council
NSERC (Canada)
Alberta Ingenuity Fund
Canada Fund for Innovation

